

# BONTEC

INSTALLATION MANUAL

## Universal TV Stand Base Table Top Stand

Model: ST-13

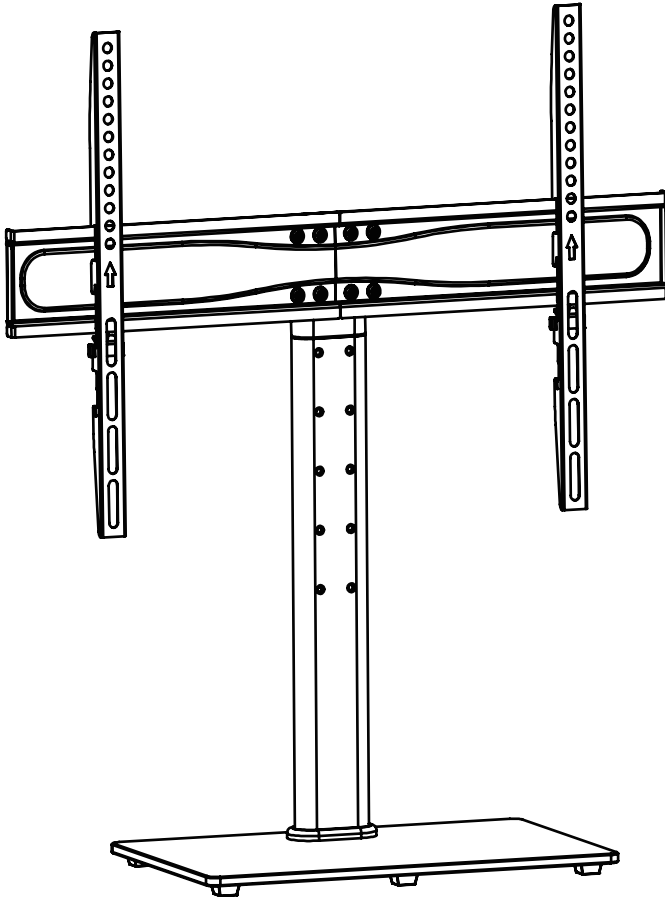

Thank you for choosing our products.

## **⚠ UNPACKING INSTRUCTIONS**

- Carefully open the carton, remove contents and lay out on cardboard or other protective surface to avoid damage.
- Check package contents against the Supplied Parts List in the next page to assure that all components were received undamaged. Do not use damaged or defective parts.
- Carefully read all instructions before attempting installation.

## **⚠ IMPORTANT SAFETY INFORMATION**

Install and operate this device with care. Please read this instruction before beginning the installation, and carefully follow all instructions contained herein. Use proper safety equipment during installation.

Please call a qualified installation contractor for help if you:

- If you don't understand these directions or have any doubts about the safety of the installation.
- If you are uncertain about the nature of your wall, consult a qualified installation contractor.

Do not use this product for any purpose or in any configuration not explicitly specified in this instruction. We hereby disclaim any and all liability for injury or damage arising from incorrect assembly, incorrect mounting, or incorrect use of this product.

## **Supplied Parts**



**TV Plate  
A (X2)**

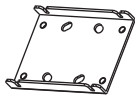

**TV Plate  
B (X1)**

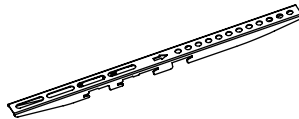

**Monitor Bracket  
C (X2)**

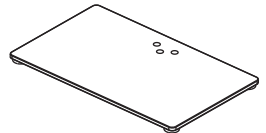

**Tempered Glass  
D (X1)**

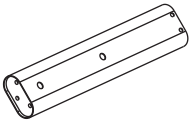

**Support Column  
E (X1)**



**Support Column  
F (X1)**

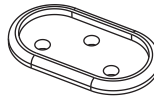

**Plastic Socket  
G (X1)**



**M6x10 Bolt  
H (X10)**

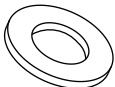

**Metal Washer  
Ø6.5 X Ø12 X 1.2  
I (X10)**

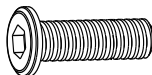

**M6x30 Bolt  
J (X3)**

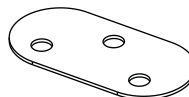

**Metal Pad  
K (X1)**

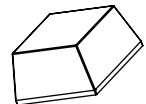

**Rubber Foot  
L (X6)**

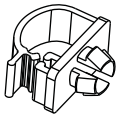

Wire Clip  
M (X2)

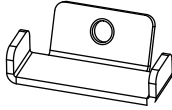

Buckle  
N (X2)



M5x30 Bolt  
O (X2)



Allen Key  
P (X1)



M4x30 Bolt  
W-A (X4)

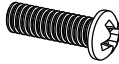

M6x15 Bolt  
W-B (X4)



M6x30 Bolt  
W-C (X4)

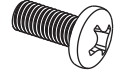

M8x20 Bolt  
W-D (X4)

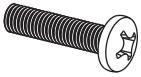

M8x50 Bolt  
W-E (X4)

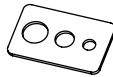

Square Washer  
W-F (X4)



5mm Spacer  
W-G (X8)

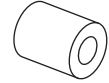

10mm Spacer  
W-H (X8)



Cable Ties  
W-I (X2)

## Step 1

## Connecting the Support Column to Tempered Glass

1.1

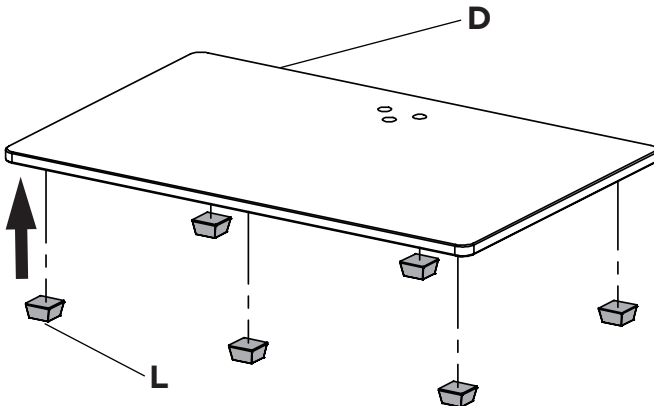

**1.2**

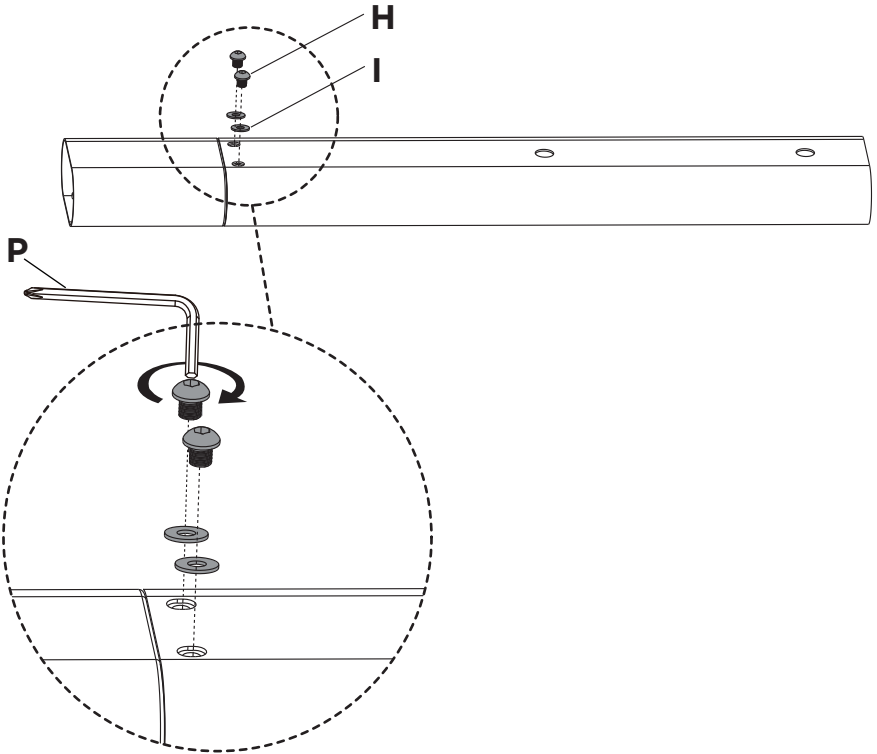
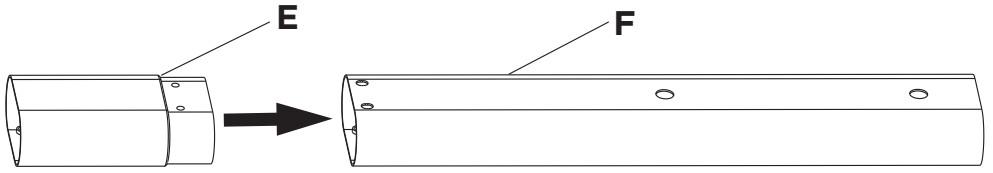

1.3

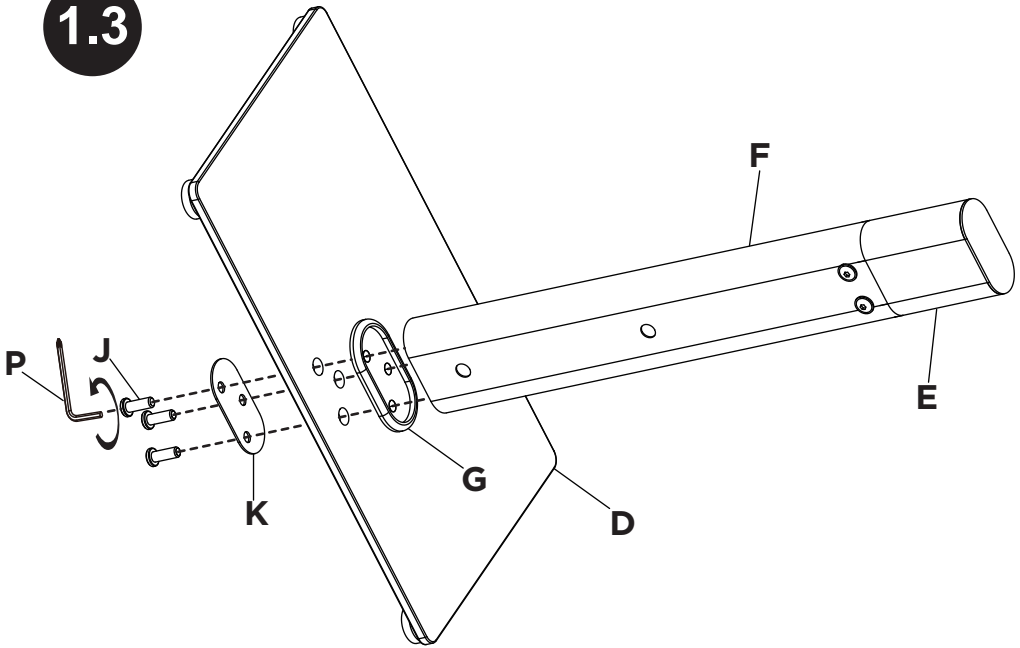

## Step 2 Connecting the TV Plate to Support Column

2.1

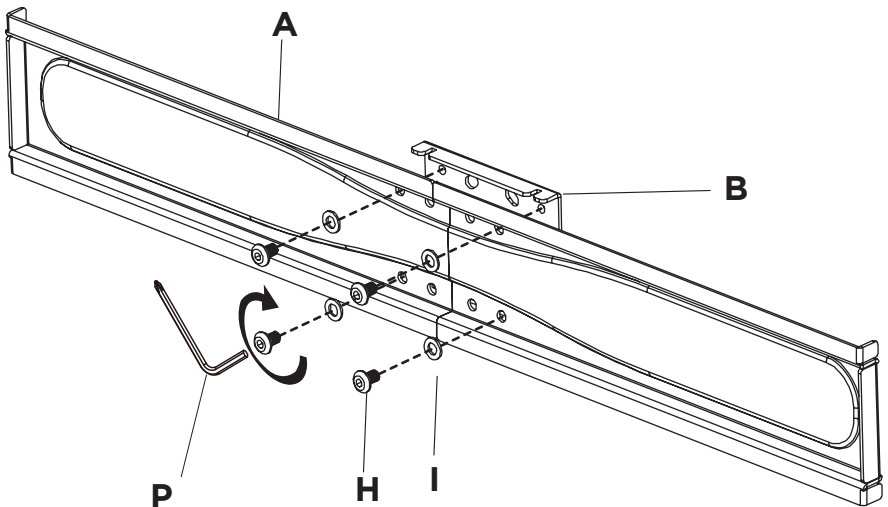

2.2

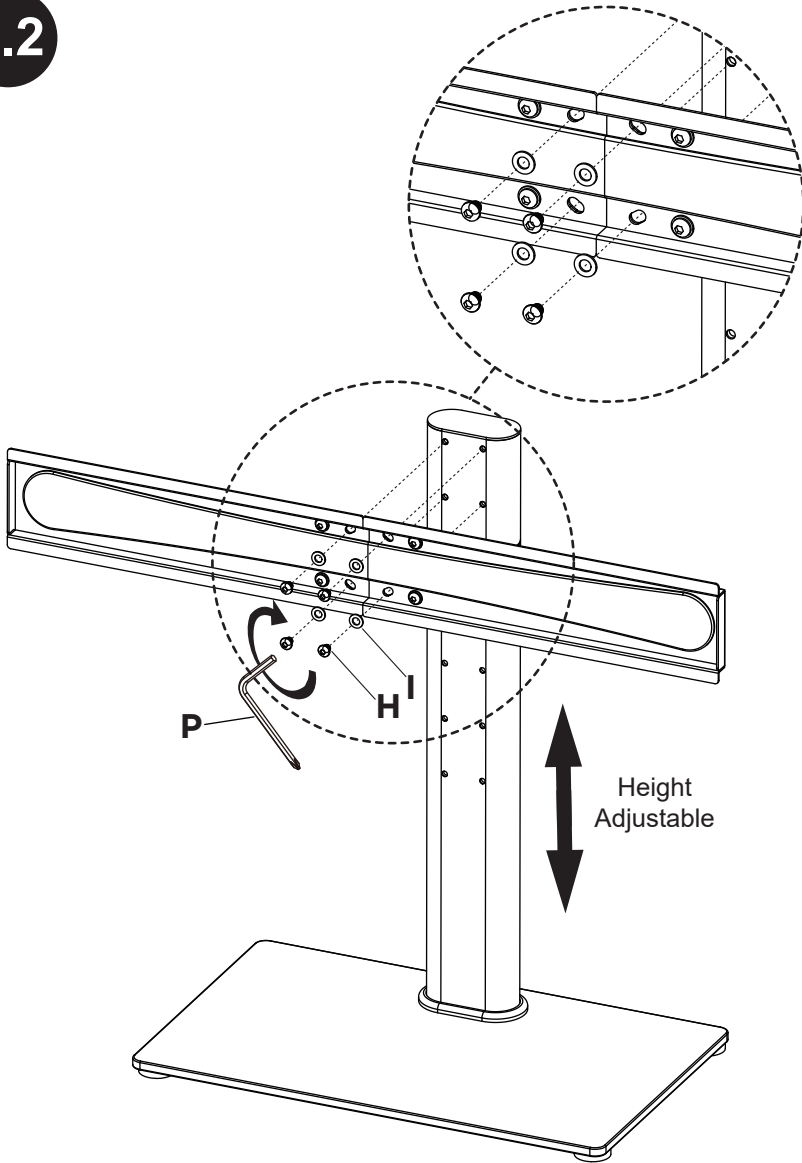

\*TV Plate can be installed on wall optionally,  
wall mounting hardware have not included.

2.3

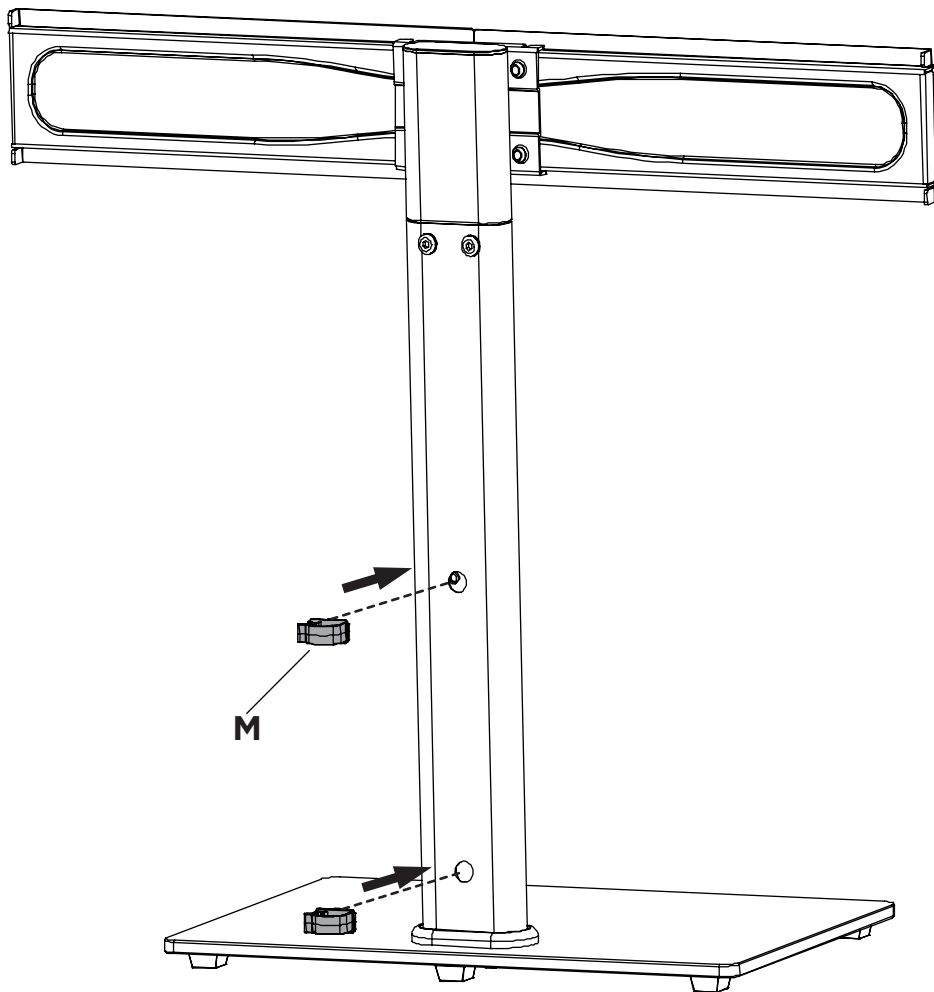

## Step 3

## Mounting the Monitor Brackets to a TV

First of all, make sure the diameter of the Bolt(**W-A** to **W-E**) your TV requires. Once you have determined the correct diameter, please see the diagram as below. You will thread the Bolt into the TV using the correct Washer(**W-F**), and using the spacer(**W-G, W-H**) if necessary. Please make sure the Monitor Brackets are vertically centered and level with each other.

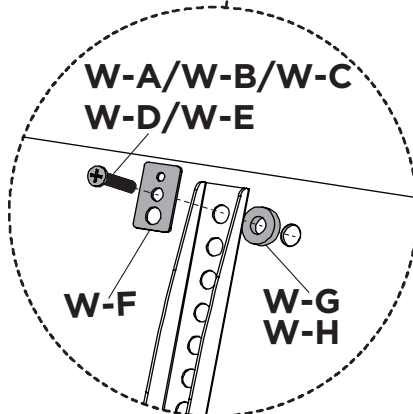
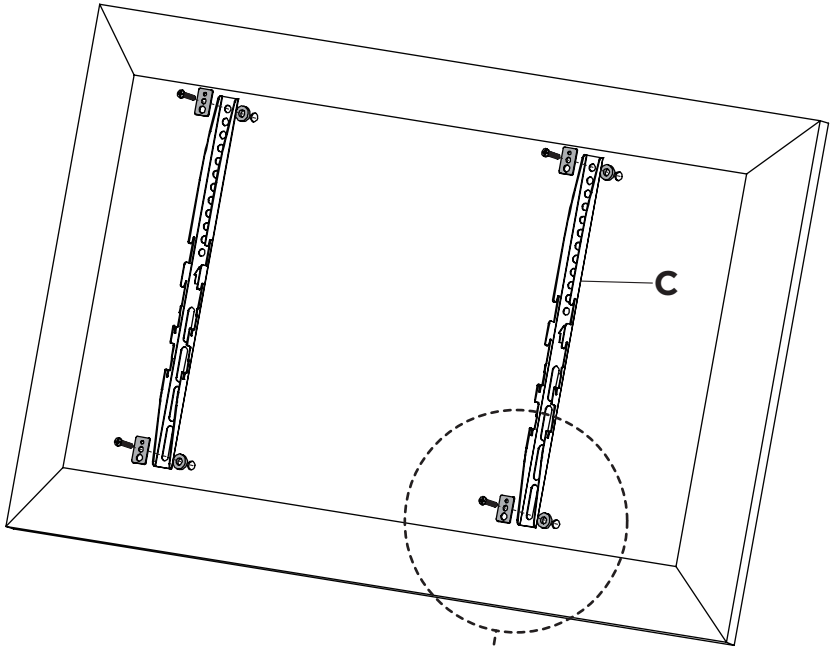



## Step 4 Attaching TV To TV Plate and Managing the Wires

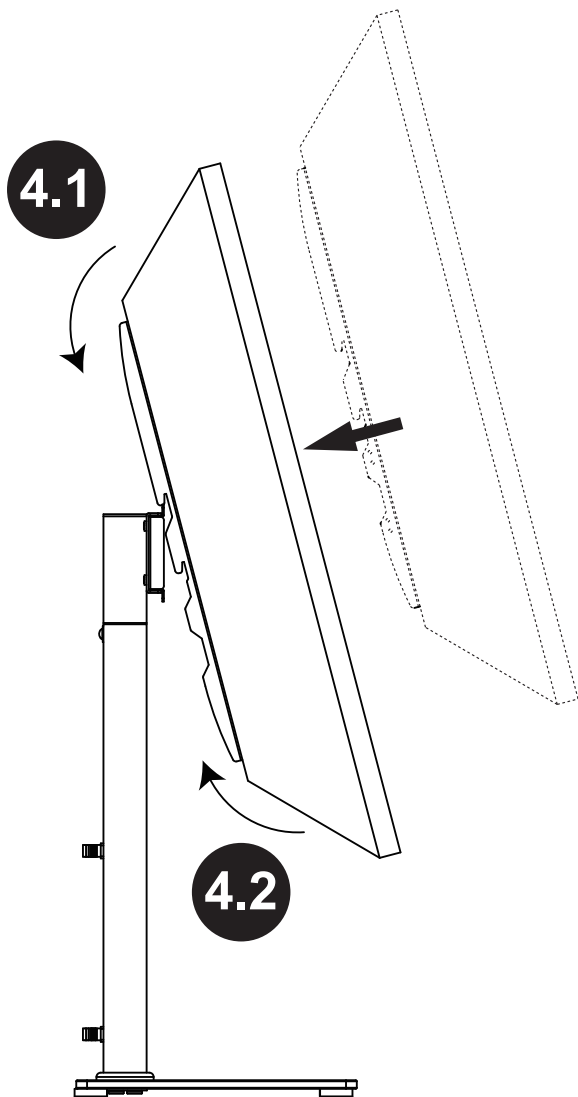

Hang the TV onto Stand, there are two gears that can be adjusted!

# 4.3

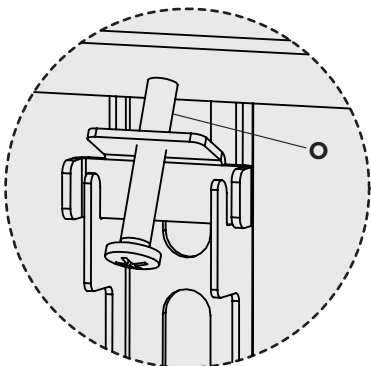
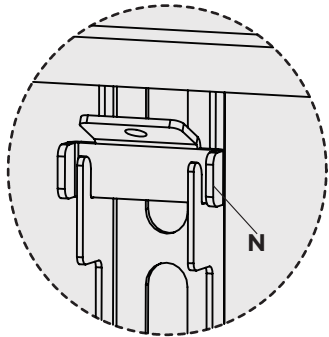
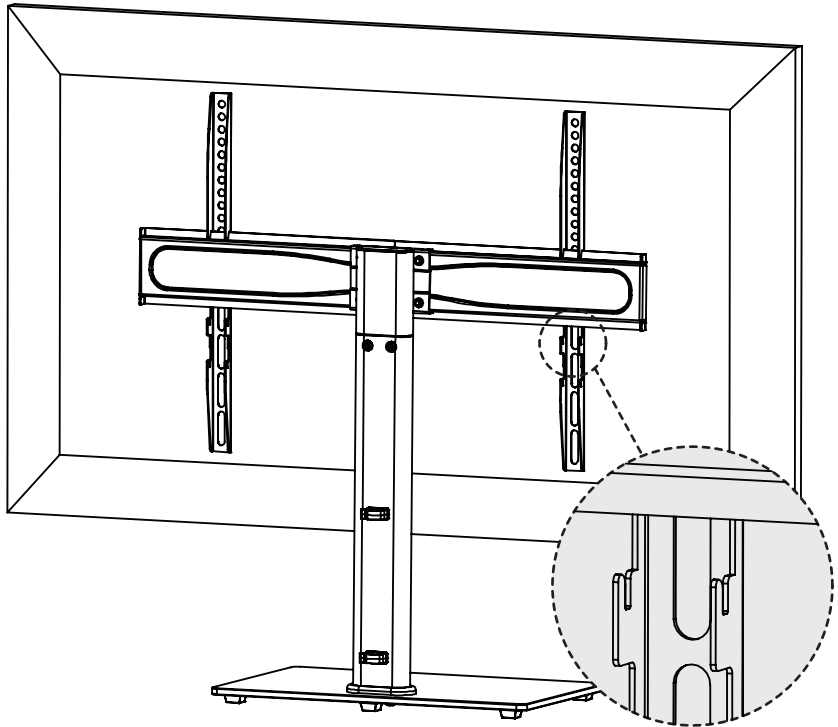

4.4

